

SS150 EXTENSIONS

TORQUE STRENGTH RATING - 7,000 FT-LB
 ULTIMATE CAPACITY*(TENSION/COMPRESSION) - 70 KIP
 * BASED ON A TORQUE FACTOR $K=10$
 SINGLE HELIX ULTIMATE STRENGTH - 40 KIP
 ULTIMATE TENSION STRENGTH (COUPLING BOLT) - 70 KIP

EXTENSION SECTION		
CAT. NO.	A	ICC-ES [†] LISTED
C150-0144	38"	X
C150-0145	59"	X
C150-0146	81"	X
C150-0175	124"	X
C150-0032	20"	
C114-0009	11"	

[†]ICC-ES LISTINGS FORMERLY ICBO, SBCCI, AND BOCA.

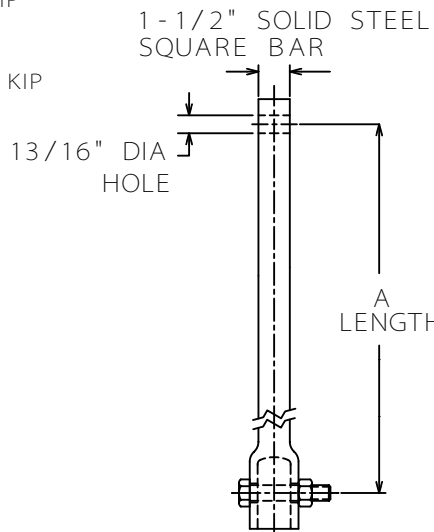

PLAIN
EXTENSION

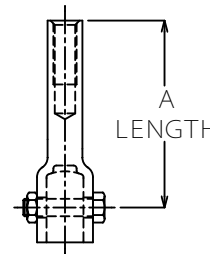

1" DYWIDAG ADAPTER
C114-0009 FOR 1-1/2" SHAFT

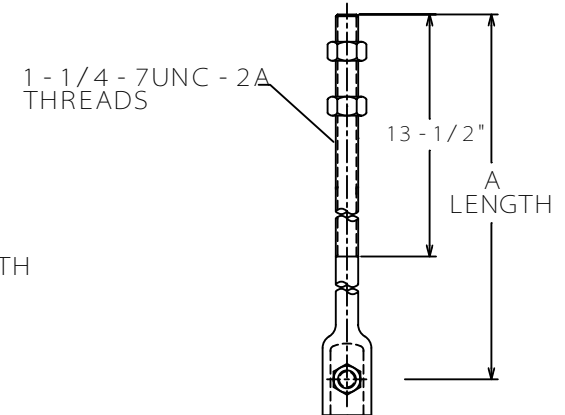

THREADED ADAPTER
C150-0032 FOR 1-1/2" SHAFT

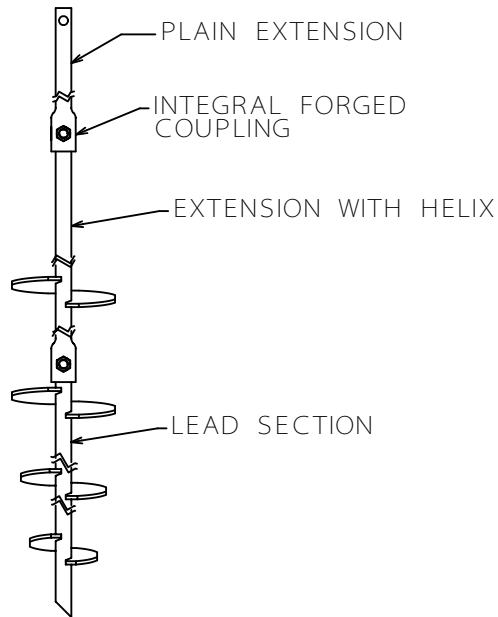

TYPICAL ANCHOR/PIER
ASSEMBLY

==NOTES==

- HOT DIP GALVANIZED PER ASTM A153 - (LATEST REVISION).
- LEAD AND EXTENSION SECTION LENGTHS AND HELIX SPACINGS ARE NOMINAL.
- SHAFT MATERIAL - HOT ROLLED ROUND-CORNERED-SQUARE (RCS) SOLID STEEL BARS PER ASTM A29; MINIMUM YIELD STRENGTH=70 KSI.
- COUPLING BOLTS: 3/4" DIAMETER X 3" LONG HEX HEAD PER ASTM A325 TYPE 1.
- MANUFACTURER TO HAVE IN EFFECT INDUSTRY RECOGNIZED WRITTEN QUALITY CONTROL FOR ALL MATERIALS AND MANUFACTURING PROCESSES.
- ALL WELDING TO BE DONE BY WELDERS CERTIFIED UNDER SECTION 5 OF THE AWS CODE D1.1.
- SEE ICC EVALUATION SERVICE INC., EVALUATION REPORT NO. ER-5110 FOR ALLOWABLE VALUES AND/OR CONDITIONS OF USE CONCERNING MATERIAL PRESENTED IN THIS DOCUMENT.
- REFER TO SA150-10013 FOR LEAD SECTIONS AND HELICAL EXTENSIONS.

ICC-ES
LISTED
RR 94-27

ICC-ES
LISTED
ER-9504

ICC-ES
LISTED
ER-5110

CHANCE		 HUBBELL POWER SYSTEM	
CONFIDENTIAL: THIS DRAWING AND ITS CONTENTS ARE CONFIDENTIAL AND THE EXCLUSIVE PROPERTY OF HUBBELL POWER SYSTEMS. NO PUBLICATION, DISTRIBUTION OR COPIES MAY BE MADE WITHOUT THE WRITTEN CONSENT OF HUBBELL POWER SYSTEMS. HUBBELL POWER SYSTEMS UNPUBLISHES ALL RIGHTS RESERVED UNDER THE COPYRIGHT LAWS.		TITLE SS150 EXTENSIONS	
SIZE	DWG NO.	CAT / PART / ASSY NO.	REV
DO NOT SCALE THIS DRAWING	SC SA150-0144	SEE CHART	B
DRN BY KSH	DATE 4/26/05	SHEET 2/2	

SS150 EXTENSIONS

TORQUE STRENGTH RATING - 7,000 FT-LB
 ULTIMATE CAPACITY *(TENSION/COMPRESSION) - 70 KIP
 * BASED ON A TORQUE FACTOR $\phi = 10$
 SINGLE HELIX ULTIMATE STRENGTH - 40 KIP
 ULTIMATE TENSION STRENGTH (COUPLING BOLT) - 70 KIP

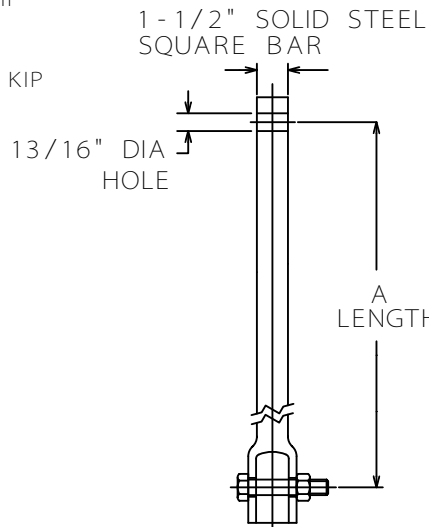

PLAIN
EXTENSION

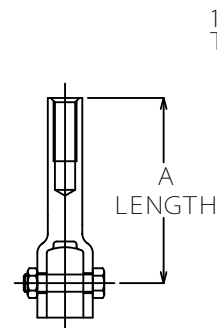

1" DYWIDAG ADAPTER
C114 - 0009 FOR 1 - 1/2" SHAFT

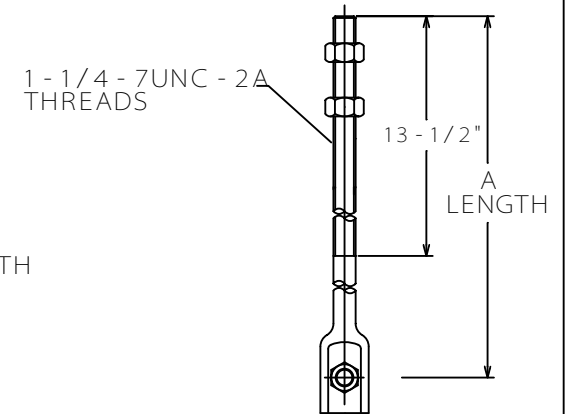

THREADED ADAPTER
C150 - 0032 FOR 1 - 1/2" SHAFT

EXTENSION SECTION		
CAT. NO.	A	ICC - ES† LISTED
C150 - 0144	38"	X
C150 - 0145	59"	X
C150 - 0146	81"	X
C150 - 0175	124"	X
C150 - 0032	20"	
C114 - 0009	11"	

† ICC - ES LISTINGS FORMERLY ICBO, SBCCI, AND BOCA.

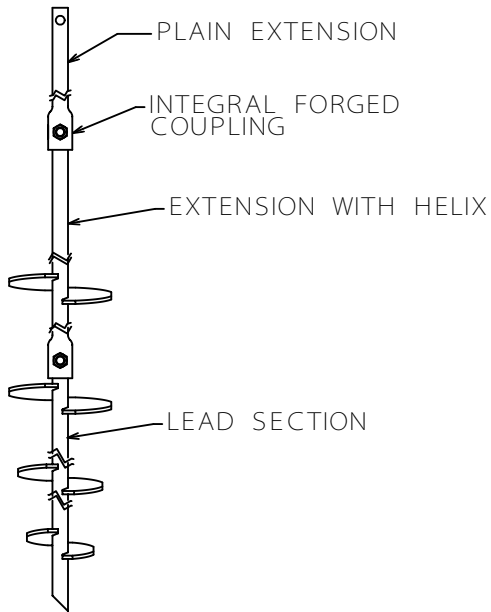

TYPICAL ANCHOR/PIER
ASSEMBLY

==NOTES==

- HOT DIP GALVANIZED PER ASTM A153 - (LATEST REVISION).
- LEAD AND EXTENSION SECTION LENGTHS AND HELIX SPACINGS ARE NOMINAL.
- SHAFT MATERIAL - HOT ROLLED ROUND - CORNERED - SQUARE (RCS) SOLID STEEL BARS PER ASTM A29; MINIMUM YIELD STRENGTH=70 KSI.
- COUPLING BOLTS: 3/4" DIAMETER X 3" LONG HEX HEAD PER ASTM A325 TYPE 1.
- MANUFACTURER TO HAVE IN EFFECT INDUSTRY RECOGNIZED WRITTEN QUALITY CONTROL FOR ALL MATERIALS AND MANUFACTURING PROCESSES.
- ALL WELDING TO BE DONE BY WELDERS CERTIFIED UNDER SECTION 5 OF THE AWS CODE D1.1.
- SEE ICC EVALUATION SERVICE INC., EVALUATION REPORT NO. ER - 5110 FOR ALLOWABLE VALUES AND/OR CONDITIONS OF USE CONCERNING MATERIAL PRESENTED IN THIS DOCUMENT.
- REFER TO SA150 - 10013 FOR LEAD SECTIONS AND HELICAL EXTENSIONS.

ICC - ES
LISTED
RR 94 - 27

ICC - ES
LISTED
ER - 9504

ICC - ES
LISTED
ER - 5110

CHANCE		 HUBBELL POWER SYSTEMS	
CONFIDENTIAL: THIS DRAWING AND ITS CONTENTS ARE CONFIDENTIAL AND THE EXCLUSIVE PROPERTY OF HUBBELL POWER SYSTEMS. NO PUBLICATION, DISTRIBUTION OR COPIES MAY BE MADE WITHOUT THE WRITTEN CONSENT OF HUBBELL POWER SYSTEMS. HUBBELL POWER SYSTEMS UNPUBLISHES ALL RIGHTS RESERVED UNDER THE COPYRIGHT LAWS.		TITLE SS150 EXTENSIONS	
SIZE SC	DWG NO. SA150 - 0144	CAT / PART / ASSY NO. SEE CHART	REV B
DO NOT SCALE THIS DRAWING	DRN BY KSH	DATE 4/26/05	SHEET 2/2