

RS2875.203

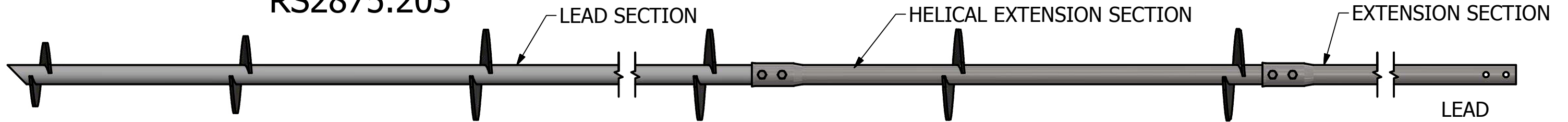

HSS 2.5 INCH SCH 40
 TORQUE: 7000 FT-LBS
 TENSION/ COMPRESSION*: 63 KIP
 COUPLING ULTIMATE TENSION: 105 KIP
 *BASED ON A K_t = 9 FT-1

*** * NOTES * ***

1. HOT DIP GALVANIZED PER ASTM A123
2. LEAD AND EXTENSION SECTION LENGTHS AND HELIX SPACINGS ARE NOMINAL
3. PIPE SHAFT MATERIAL PER ASTM A618 OR A500 GRADE B/C MIN YIELD 65KSI.
4. HELIX MATERIAL LOW CARBON STEEL MEETING THE GENERAL REQUIREMENTS OF AISI OR ASTM A572, A656, OR A1018
5. COUPLING BOLTS: 0.75" DIAMETER X 4-1/4" LONG HEX HEAD PER SAE J425 GRADE 5
6. MANUFACTURER TO HAVE IN EFFECT INDUSTRY RECOGNIZED WRITTEN QUALITY CONTROL FOR ALL MATERIALS AND MANUFACTURING PROCESSES
7. ALL WELDING TO BE DONE BY WELDERS CERTIFIED UNDER SECTION 5 OF THE AWS CODE D1.1.
8. ALL MEASUREMENTS ARE IN INCHES UNLESS SPECIFIED.
9. HARDWARE IS PROVIDED WITH EXTENSIONS AND HELICAL EXTENSION SECTIONS.
10. HELIX SPACING IS THREE DIAMETERS OF LOWER HELIX.

HELICAL EXTENSION SECTION

EXTENSION SECTION

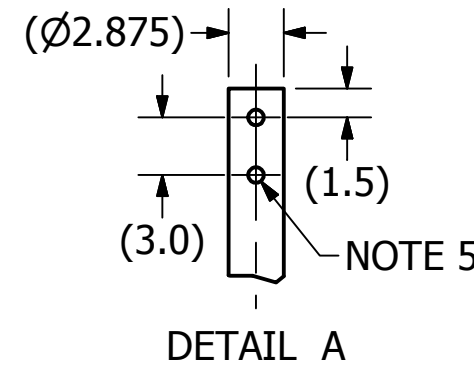
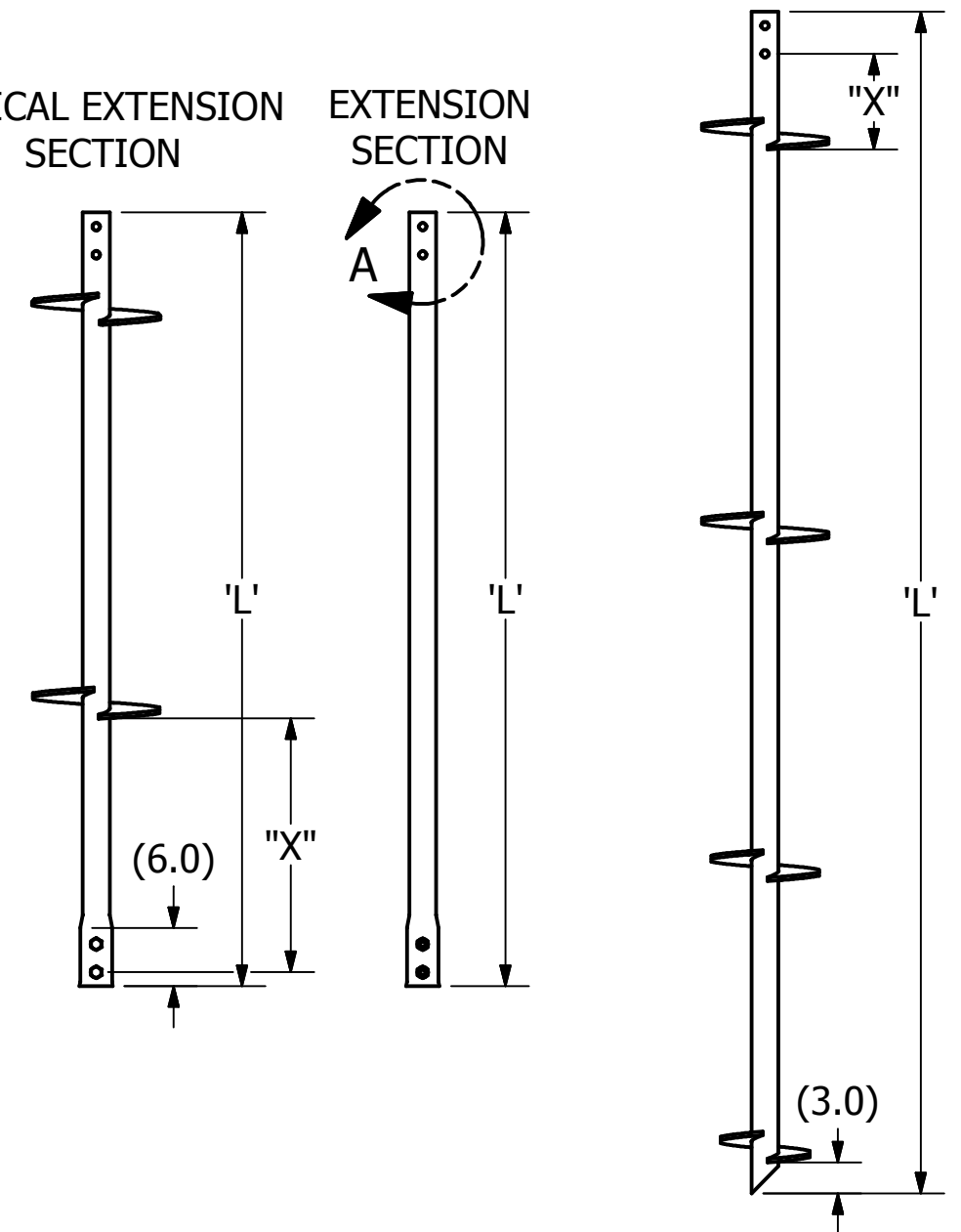

CATALOG NUM	DESCRIPTION	'A'	'B'	'C'	'D'	'L' (FT)	"X"
C2784512	LEAD, RS2875.203, 8/10 X 5FT	8	10	-	-	5	24
C2784513	LEAD, RS2875.203, 8/10 X 7FT	8	10	-	-	7	-
C2784514	LEAD, RS2875.203, 8/10/12 X 5FT	8	10	12	-	5	21
C2784510	LEAD, RS2875.203, 10 X 5FT	10	-	-	-	5	-
C2784504	LEAD, RS2875.203, 10 X 5FT	10	-	-	-	5	-
C2784519	LEAD, RS2875.203, 10 X 7FT	10	-	-	-	7	-
C2784505	LEAD, RS2875.203, 10/12 X 5FT	10	12	-	-	5	-
C2784506	LEAD, RS2875.203, 10/12 X 7FT	10	12	-	-	7	30
C2784507	LEAD, RS2875.203, 10/12/14 X 7FT	10	12	14	-	7	30
C2784508	LEAD, RS2875.203, 10/12/14/14 X 10FT	10	12	14	14	10	-
C2784503	LEAD, RS2875.203, 12 X 5FT	12	-	-	-	5	-
C2784509	LEAD, RS2875.203, 12 X 7FT	12	-	-	-	7	-
C2784511	LEAD, RS2875.203, 14 X 7FT	14	-	-	-	7	-
C2784515	LEAD, RS2875.203, 14 X 10FT	14	-	-	-	10	-
C2784300CU	EXTENSION, RS2875.203 3.5FT CU	-	-	-	-	3.5	-
C2784500CU	EXTENSION, RS2875.203 5FT CU	-	-	-	-	5	-
C2784700CU	EXTENSION, RS2875.203 7FT CU	-	-	-	-	7	-
C27841000CU	EXTENSION, RS2875.203 10FT CU	-	-	-	-	10	-
C2784501CU	EXTENSION, RS2875.203, 14 X 5FT, CU	14	-	-	-	5	-
C2784502CU	EXTENSION, RS2875.203, 14/14 X 7FT, CU	14	14	-	-	7	-

CHANCE [®] <small>CONFIDENTIAL: THIS DRAWING AND ITS CONTENTS ARE CONFIDENTIAL AND THE EXCLUSIVE PROPERTY OF HUBBELL POWER SYSTEMS. NO PUBLICATION, DISTRIBUTION, OR COPIES MAY BE MADE WITHOUT THE WRITTEN CONSENT OF HUBBELL POWER SYSTEMS. HUBBELL POWER SYSTEMS UNPUBLISHED ALL RIGHTS RESERVED UNDER THE COPYRIGHT LAWS.</small>	HUBBELL [®] <small>POWER SYSTEMS, INC.</small>	HUBBELL POWER SYSTEMS, INC.		
	TITLE HELICAL PIER RS2875.203			
SIZE B	CAT / PART / ASSY NO. SEE CHART	DWG NO. SA2784300CU	REV C	
DO NOT SCALE THIS DRAWING	DRN BY TMK	DATE 5/31/17	SHEET 1 OF 1	